



REVISION HISTORY					
ECO	SHEET	REV.	DESCRIPTION	DATE	APPR'D
		A	INITIAL RELEASE	9/15/2025	JJG
		B	CORRECTED MOUNTING HOLE CALLOUTS	11/10/2025	JJG
		C	ADD MODULE TO OAL THICKNESS DIM	12/1/2025	JJG

**PLANAR**<sup>®</sup>

PLANAR SYSTEMS, INC.  
6799 NE BENNETT STREET  
HILLSBORO, OR 97124 USA

THIS DRAWING CONTAINS INFORMATION PROPRIETARY TO PLANAR SYSTEMS, INC. ANY REPRODUCTION IN PART OR WHOLE WITHOUT THE WRITTEN PERMISSION OF PLANAR SYSTEMS IS PROHIBITED. THIS DRAWING IS SUPPLIED FOR INFORMATION, IDENTIFICATION, ENGINEERING, EVALUATION, AND/OR INSPECTION PURPOSES ONLY AND MAY NOT BE USED AS BASIS FOR THE MANUFACTURING OF PRODUCTS OR THE DESIGN OF ANY PARTS OR SYSTEMS OR TO ANY THIRD PARTY, UNLESS AUTHORIZED IN WRITING BY PLANAR SYSTEMS.

PRODUCT  
**Planar® Komodo™ Series LED**  
**Product Overview**

PART NO.

UNLESS OTHERWISE SPECIFIED DIMENSIONS ARE IN MILLIMETERS (INCHES).

SHEET TITLE  
**KOMODO 0.7**  
**OUTLINE**

DRAWN BY  
**JJG**

DRAWN DATE  
**22 Aug 25**

SHEET  
**1 OF 10**

SHEET SIZE REVISION  
**B C**

1. SPECIFICATIONS SUBJECT TO CHANGE WITHOUT NOTICE

NOTES: UNLESS OTHERWISE SPECIFIED.

4

3

2

1

D

C

B

A

1. SPECIFICATIONS SUBJECT TO CHANGE WITHOUT NOTICE

NOTES: UNLESS OTHERWISE SPECIFIED.

4

3

2

1

Sheet List Table	
Sheet Number	Sheet Title
1	KOMODO 0.7 OUTLINE
2	KEY & INDEX
3	KOMODO 0.7 OVERVIEW - PAGE 1
4	KOMODO 0.7 OVERVIEW - PAGE 2
5	KOMODO 0.7 MODULE OVERVIEW
6	KOMODO 0.7 FRONT INSTALL
7	KOMODO 0.7 REAR INSTALL
8	KOMODO 0.7 MOUNTING ACCESSORIES
9	KOMODO 0.7 8X6 MOUNT LAYOUT
10	KOMODO 0.7 TRIM



PLANAR SYSTEMS, INC.  
6799 NE BENNETT STREET  
HILLSBORO, OR 97124 USA

D

THIS DRAWING CONTAINS INFORMATION PROPRIETARY TO PLANAR SYSTEMS, INC. ANY REPRODUCTION IN PART OR WHOLE WITHOUT THE WRITTEN PERMISSION OF PLANAR SYSTEMS IS PROHIBITED. THIS DRAWING IS SUPPLIED FOR INFORMATION, IDENTIFICATION, ENGINEERING, EVALUATION, AND/OR INSPECTION PURPOSES ONLY AND MAY NOT BE USED AS BASIS FOR THE MANUFACTURING OF PRODUCTS OR THE INSTALLATION OF ANY PARTS. PLANAR SYSTEMS OR ITS ANY THIRD PARTY, IN LESS AUTHORIZED IN WRITING BY PLANAR SYSTEMS.

C

PRODUCT  
**Planar® Komodo™ Series LED  
Product Overview**

PART NO.

-

B

SHEET TITLE  
**KEY & INDEX**

UNLESS OTHERWISE SPECIFIED DIMENSIONS ARE IN MILLIMETERS (INCHES).

A

DRAWN BY

JJG

DRAWN DATE

22 Aug 25

SHEET

2 OF 10

SHEET SIZE

B

REVISION

C

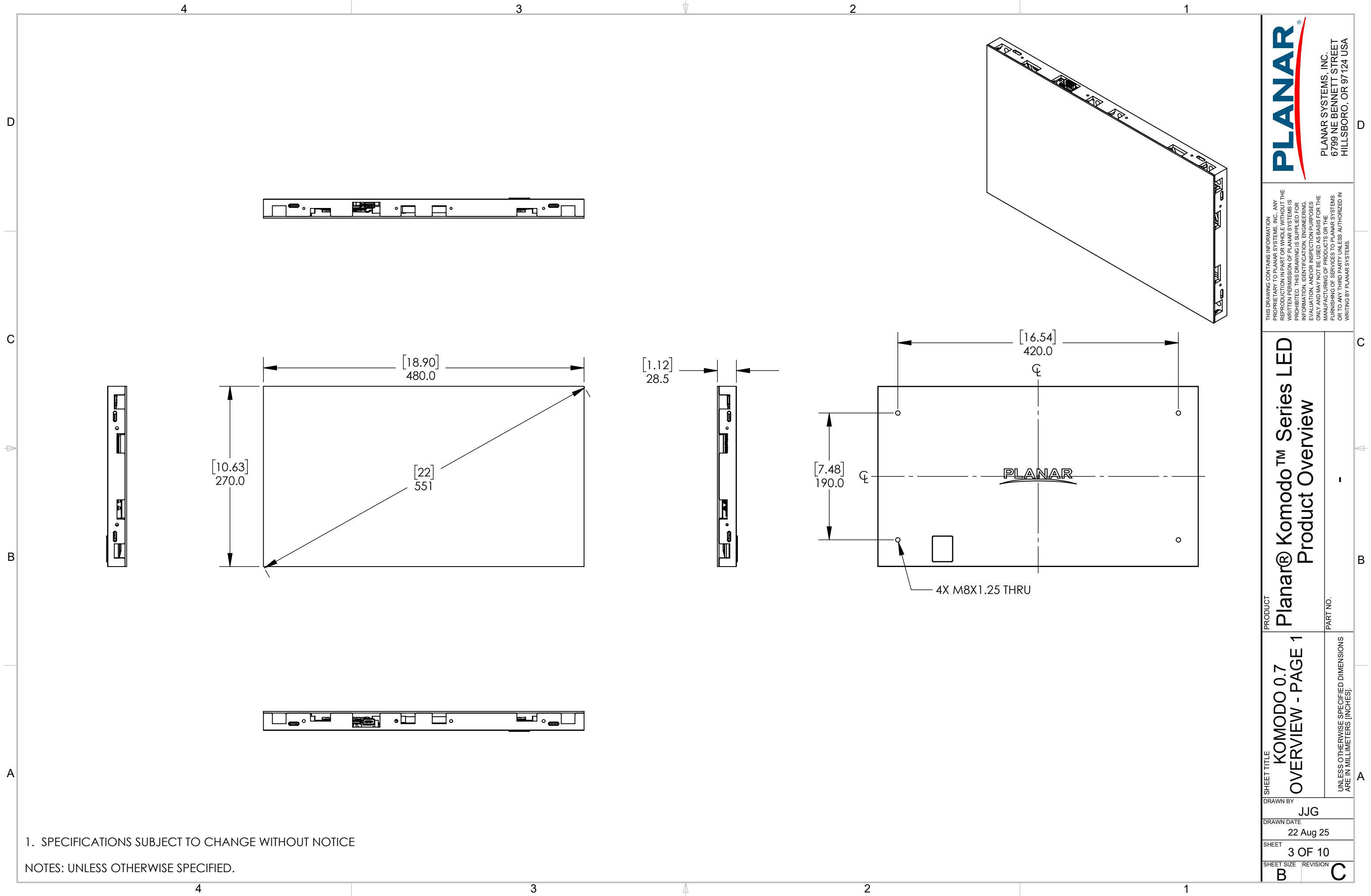

1. SPECIFICATIONS SUBJECT TO CHANGE WITHOUT NOTICE

NOTES: UNLESS OTHERWISE SPECIFIED.

**PLANAR**

PLANAR SYSTEMS, INC.  
6799 NE BENNETT STREET  
HILLSBORO, OR 97124 USA

THIS DRAWING CONTAINS INFORMATION PROPRIETARY TO PLANAR SYSTEMS, INC. ANY REPRODUCTION IN PART OR WHOLE WITHOUT THE WRITTEN PERMISSION OF PLANAR SYSTEMS IS PROHIBITED. THIS DRAWING IS SUPPLIED FOR INFORMATION, IDENTIFICATION, ENGINEERING, EVALUATION, AND/OR INSPECTION PURPOSES ONLY AND MAY NOT BE USED AS BASIS FOR THE MANUFACTURING OF PRODUCTS OR THE DESIGN OF ANY THIRD PARTY UNLESS AUTHORIZED IN WRITING BY PLANAR SYSTEMS.

PRODUCT  
**Planar® Komodo™ Series LED**  
Product Overview

SHEET TITLE  
**KOMODO 0.7**  
OVERVIEW - PAGE 1

DRAWN BY  
**JJG**

DRAWN DATE  
**22 Aug 25**

SHEET  
**3 OF 10**

SHEET SIZE REVISION  
**B C**

UNLESS OTHERWISE SPECIFIED DIMENSIONS ARE IN MILLIMETERS (INCHES).

PART NO.  
-

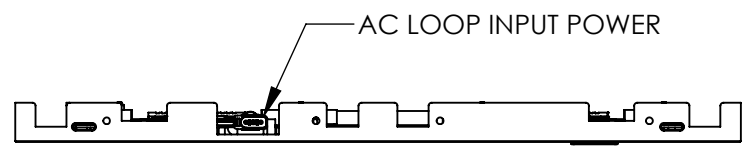
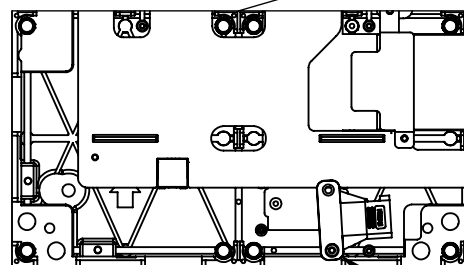
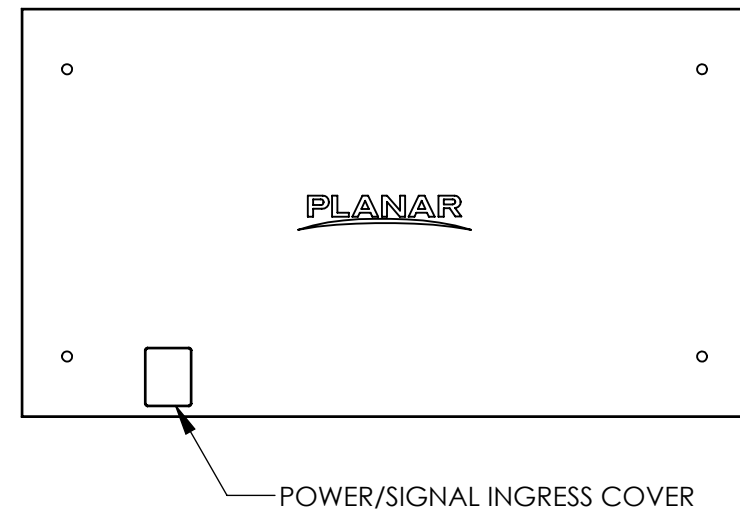
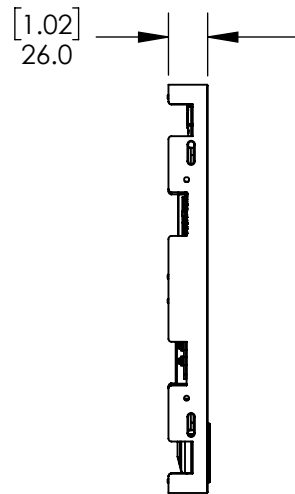
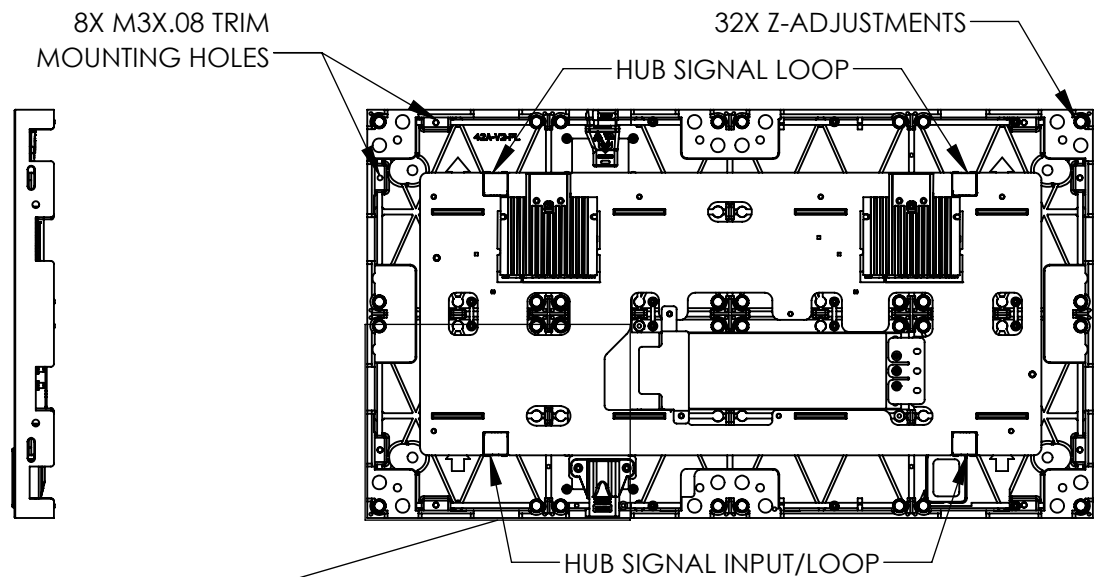
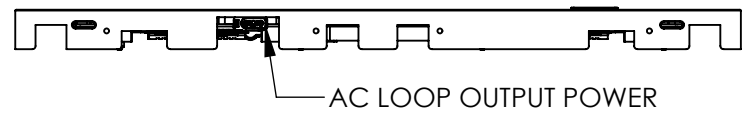

\*MAIN POWER ENTRY CONFIGURATION LOCATION

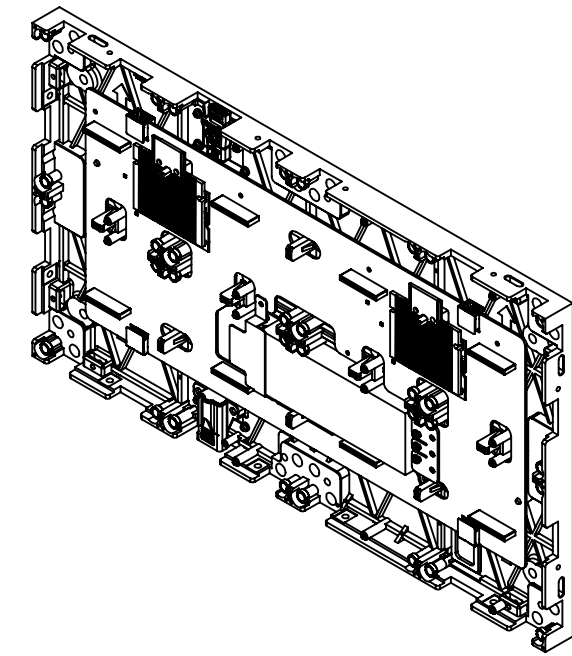

2. \*FOR STARTING A POWER CHAIN THE AC POWER INPUT CONNECTOR REQUIRES INTERNAL CABINET RECONFIGURATION, SEE INSTALLATION GUIDE.  
 1. SPECIFICATIONS SUBJECT TO CHANGE WITHOUT NOTICE

NOTES: UNLESS OTHERWISE SPECIFIED.

**PLANAR®**

PLANAR SYSTEMS, INC.  
 6799 NE BENNETT STREET  
 HILLSBORO, OR 97124 USA

THIS DRAWING CONTAINS INFORMATION PROPRIETARY TO PLANAR SYSTEMS, INC. ANY REPRODUCTION IN PART OR WHOLE WITHOUT THE WRITTEN PERMISSION OF PLANAR SYSTEMS IS PROHIBITED. THIS DRAWING IS SUPPLIED FOR INFORMATION, IDENTIFICATION, ENGINEERING, EVALUATION, AND/OR INSPECTION PURPOSES ONLY AND MAY NOT BE USED AS BASIS FOR THE MANUFACTURING OF PRODUCTS OR THE DESIGN OF ANY THIRD PARTY UNLESS AUTHORIZED IN WRITING BY PLANAR SYSTEMS.

PRODUCT  
**Planar® Komodo™ Series LED**  
**Product Overview**

PART NO.

SHEET TITLE  
**KOMODO 0.7**  
**OVERVIEW - PAGE 2**

UNLESS OTHERWISE SPECIFIED DIMENSIONS ARE IN MILLIMETERS [INCHES].

DRAWN BY  
**JJG**

DRAWN DATE  
 22 Aug 25

SHEET  
**4 OF 10**

SHEET SIZE REVISION

B

C

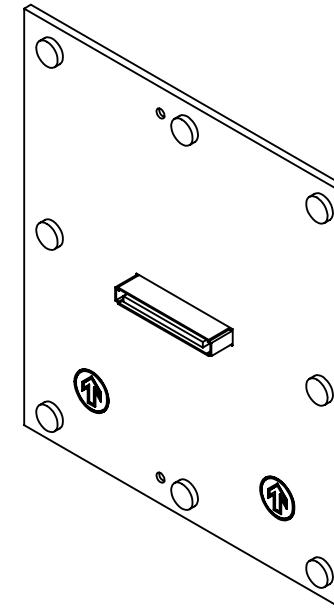
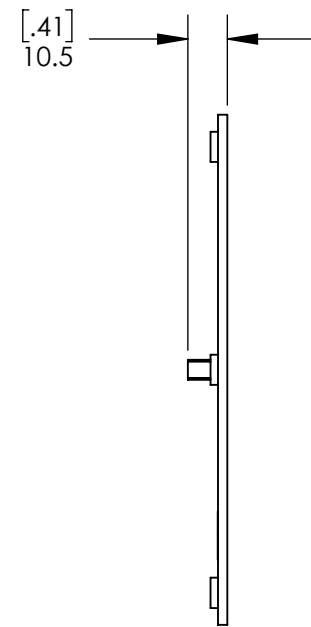
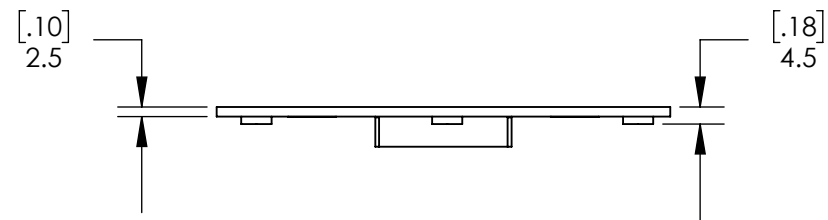
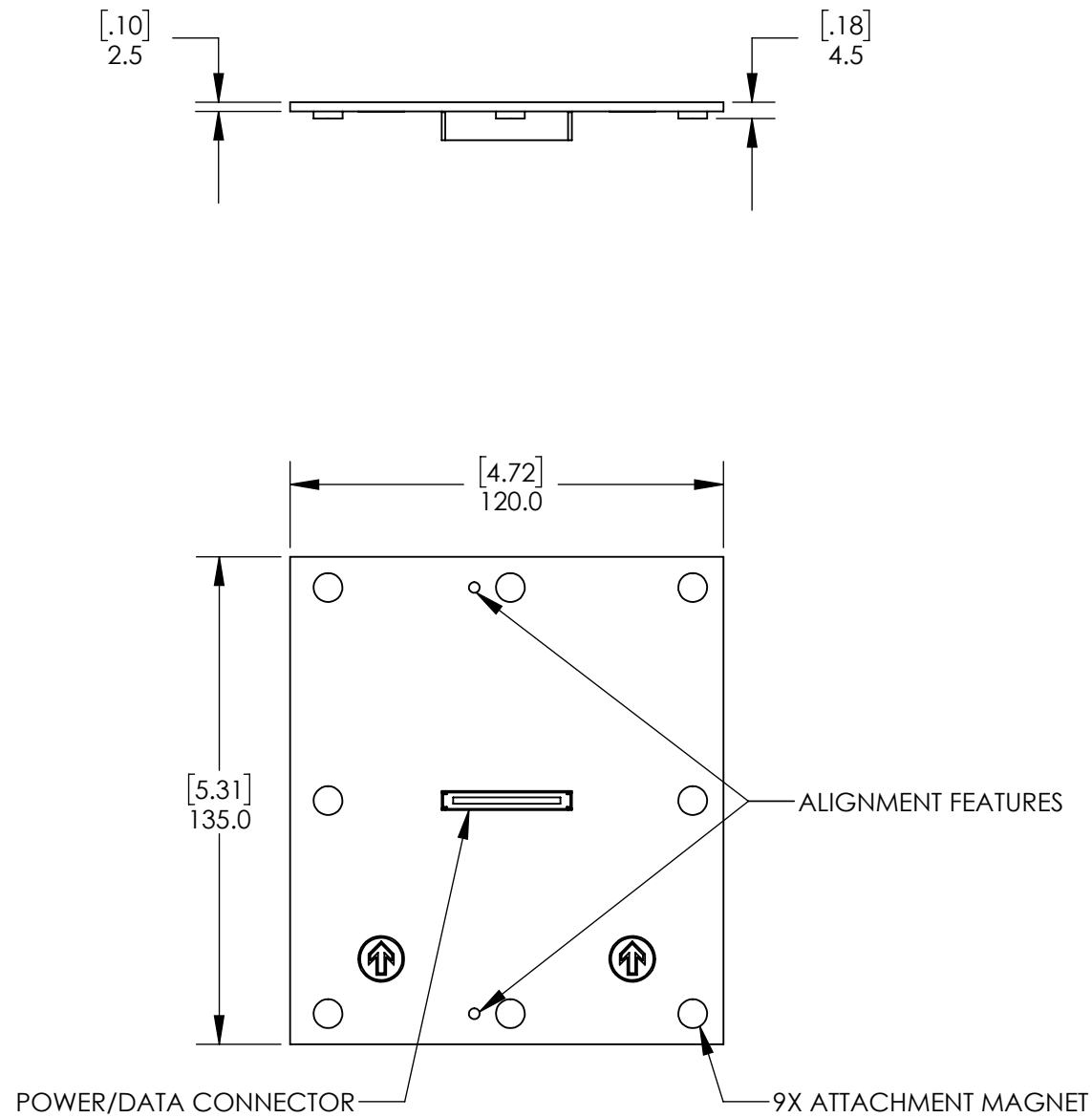

1. SPECIFICATIONS SUBJECT TO CHANGE WITHOUT NOTICE  
 NOTES: UNLESS OTHERWISE SPECIFIED.

**PLANAR**  
 PLANAR SYSTEMS, INC.  
 6799 NE BENNETT STREET  
 HILLSBORO, OR 97124 USA

THIS DRAWING CONTAINS INFORMATION PROPRIETARY TO PLANAR SYSTEMS, INC. ANY REPRODUCTION IN PART OR WHOLE WITHOUT THE WRITTEN PERMISSION OF PLANAR SYSTEMS IS PROHIBITED. THIS DRAWING IS SUPPLIED FOR INFORMATION, IDENTIFICATION, ENGINEERING, EVALUATION, AND/OR INSPECTION PURPOSES ONLY AND MAY NOT BE USED AS BASIS FOR THE MANUFACTURING OF PRODUCTS OR THE DESIGN OF ANY THIRD PARTY UNLESS AUTHORIZED IN WRITING BY PLANAR SYSTEMS.

PRODUCT  
**Planar® Komodo™ Series LED**  
**Module Overview**

PART NO.

-

SHEET TITLE  
**KOMODO 0.7**  
**MODULE OVERVIEW**

UNLESS OTHERWISE SPECIFIED DIMENSIONS ARE IN MILLIMETERS (INCHES).

DRAWN BY  
**JJG**

DRAWN DATE  
 22 Aug 25

SHEET  
 5 OF 10

SHEET SIZE REVISION  
**B C**

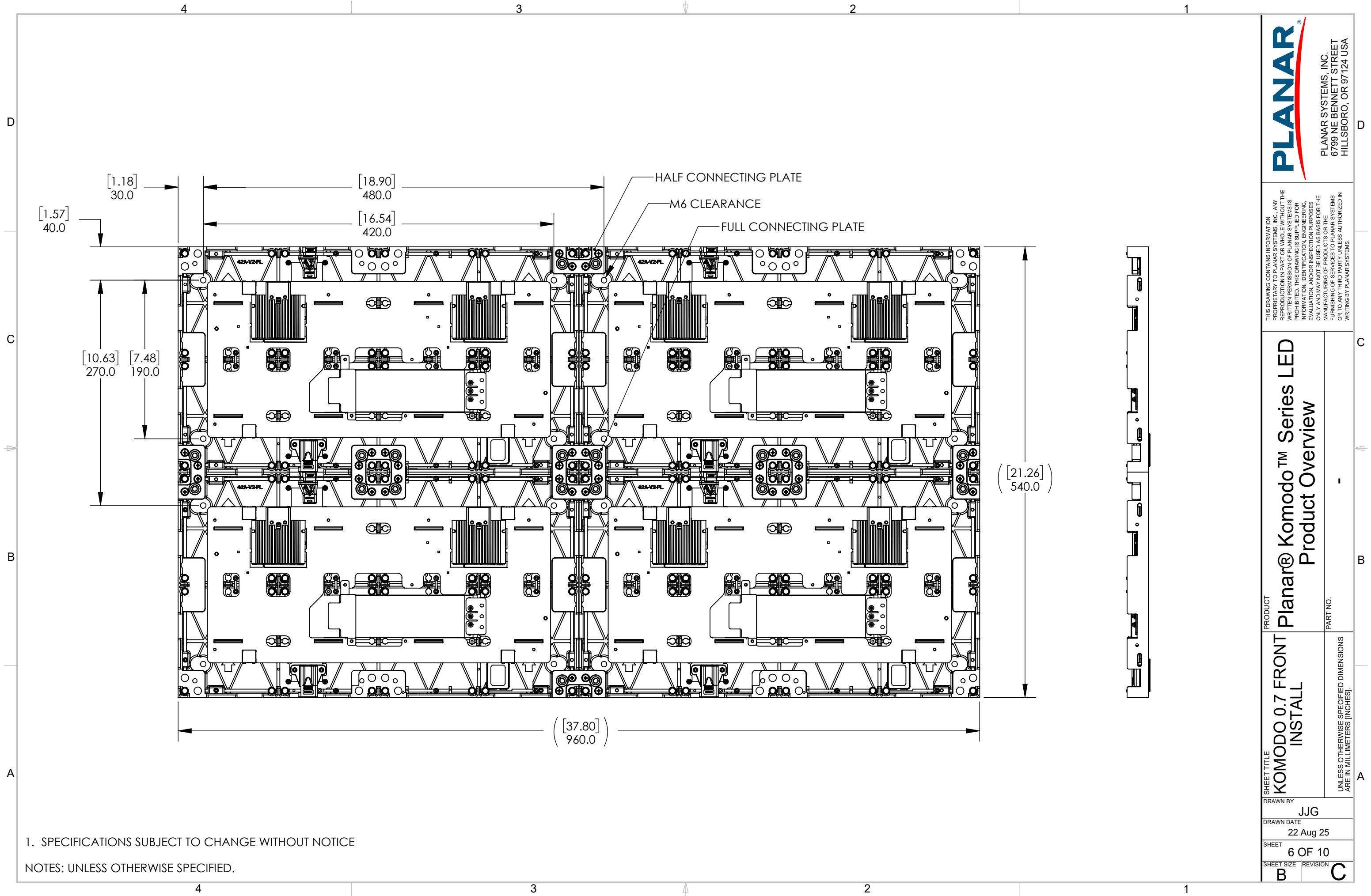

THIS DRAWING CONTAINS INFORMATION PROPRIETARY TO PLANAR SYSTEMS, INC. ANY REPRODUCTION IN PART OR WHOLE WITHOUT THE WRITTEN PERMISSION OF PLANAR SYSTEMS IS PROHIBITED. THIS DRAWING IS SUPPLIED FOR INFORMATION, IDENTIFICATION, ENGINEERING, EVALUATION, AND/OR INSPECTION PURPOSES ONLY AND MAY NOT BE USED AS BASIS FOR THE MANUFACTURING OF PRODUCTS OR THE DESIGN OF ANY THIRD PARTY PRODUCTS UNLESS AUTHORIZED IN WRITING BY PLANAR SYSTEMS.

PRODUCT  
**Planar® Komodo™ Series LED**  
**Product Overview**

SHEET TITLE  
**KOMODO 0.7 FRONT INSTALL**

UNLESS OTHERWISE SPECIFIED DIMENSIONS ARE IN MILLIMETERS (INCHES).

DRAWN BY  
**JJG**

DRAWN DATE  
**22 Aug 25**

SHEET  
**6 OF 10**

SHEET SIZE REVISION  
**B C**

1. SPECIFICATIONS SUBJECT TO CHANGE WITHOUT NOTICE  
 NOTES: UNLESS OTHERWISE SPECIFIED.

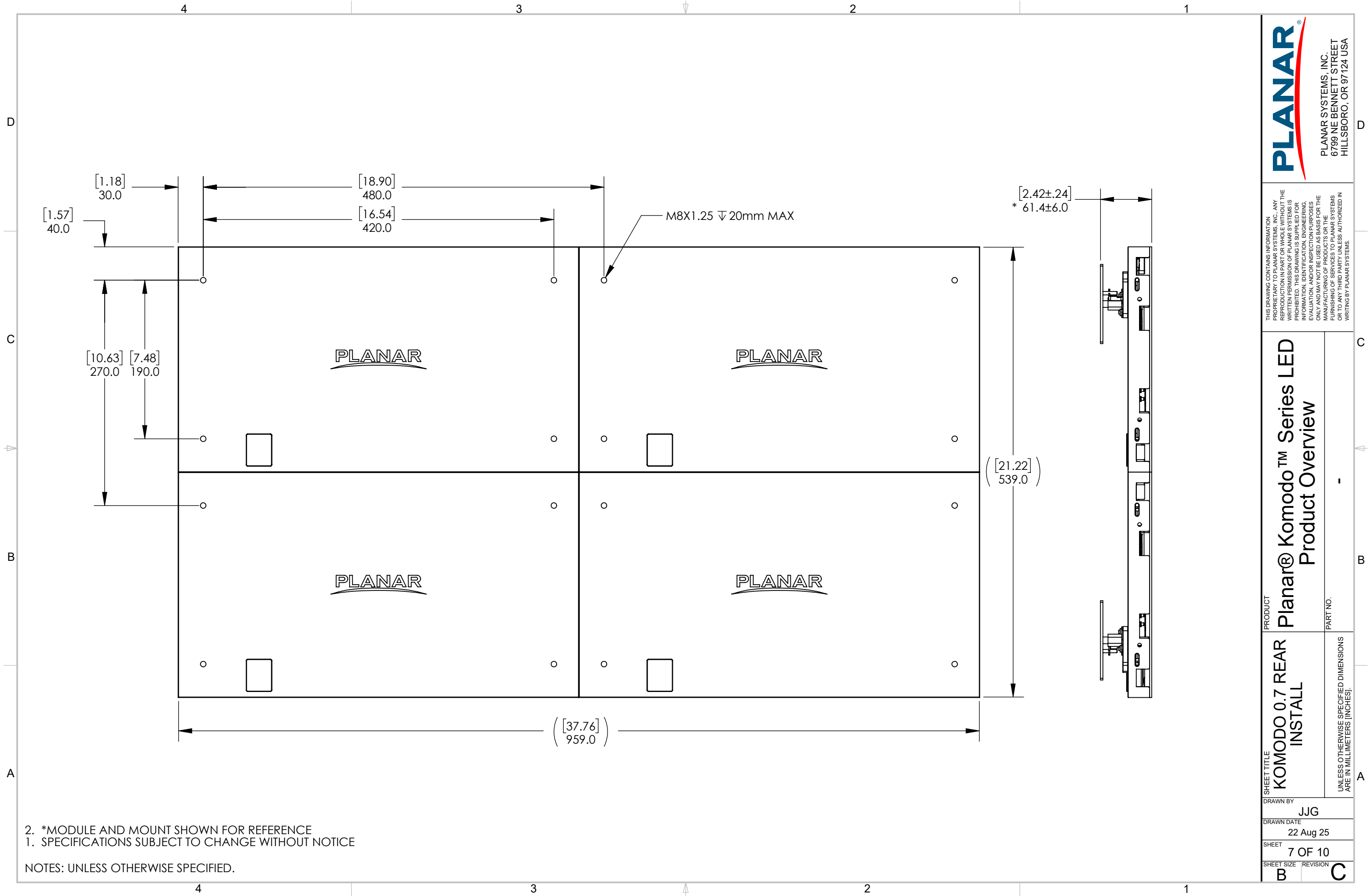

2. \*MODULE AND MOUNT SHOWN FOR REFERENCE  
 1. SPECIFICATIONS SUBJECT TO CHANGE WITHOUT NOTICE

NOTES: UNLESS OTHERWISE SPECIFIED.

THIS DRAWING CONTAINS INFORMATION PROPRIETARY TO PLANAR SYSTEMS, INC. ANY REPRODUCTION IN PART OR WHOLE WITHOUT THE WRITTEN PERMISSION OF PLANAR SYSTEMS IS PROHIBITED. THIS DRAWING IS SUPPLIED FOR INFORMATION, IDENTIFICATION, ENGINEERING, EVALUATION, AND/OR INSPECTION PURPOSES ONLY AND MAY NOT BE USED AS BASIS FOR THE MANUFACTURING OF PRODUCTS OR THE DESIGN OF ANY THIRD PARTY, UNLESS AUTHORIZED IN WRITING BY PLANAR SYSTEMS.

PRODUCT	Planar® Komodo™ Series LED Product Overview
PART NO.	-

SHEET TITLE	KOMODO 0.7 REAR INSTALL
UNLESS OTHERWISE SPECIFIED DIMENSIONS ARE IN MILLIMETERS (INCHES).	

DRAWN BY	JJG
DRAWN DATE	22 Aug 25
SHEET	7 OF 10
SHEET SIZE	REVISION
B	C

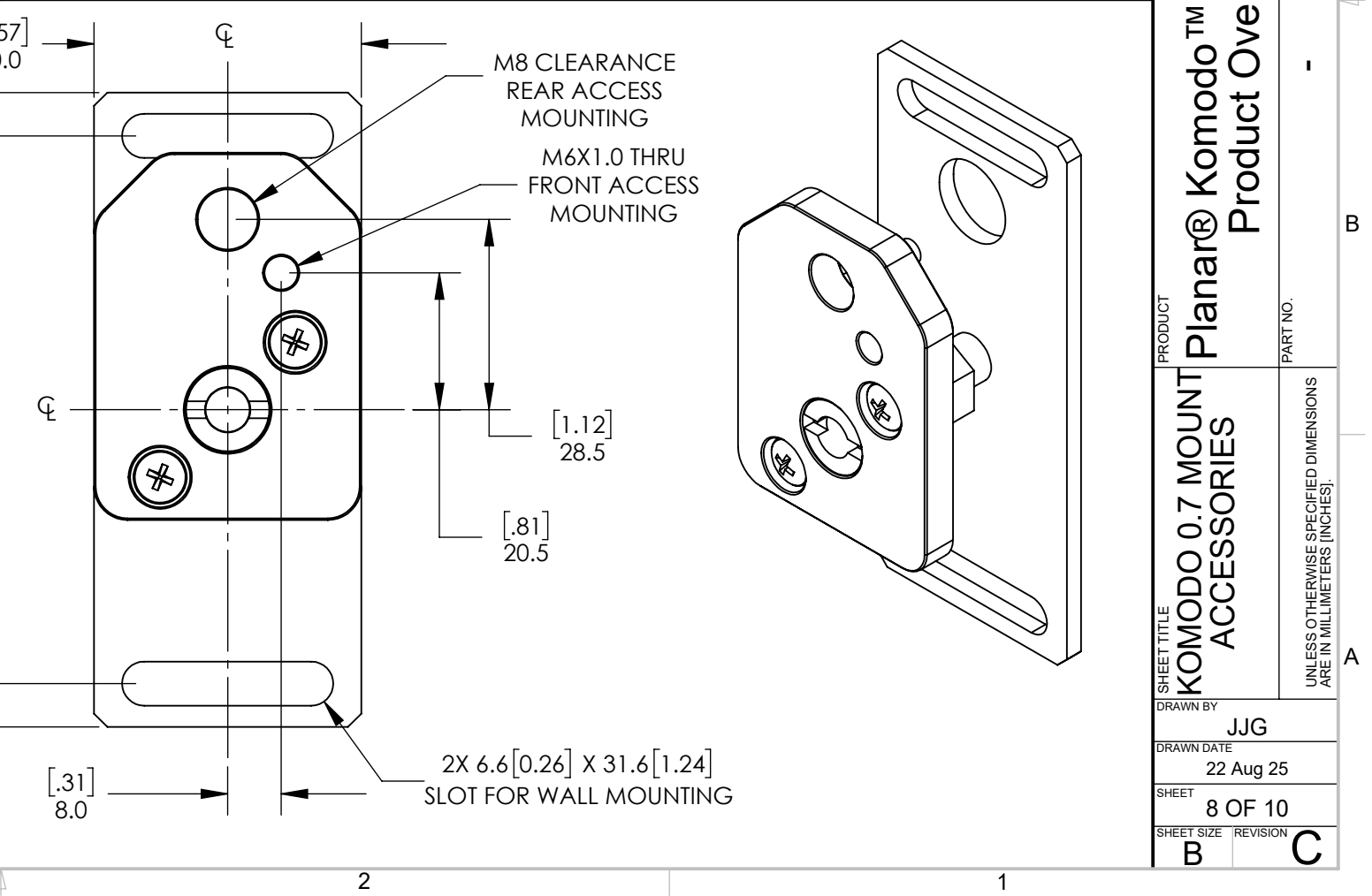
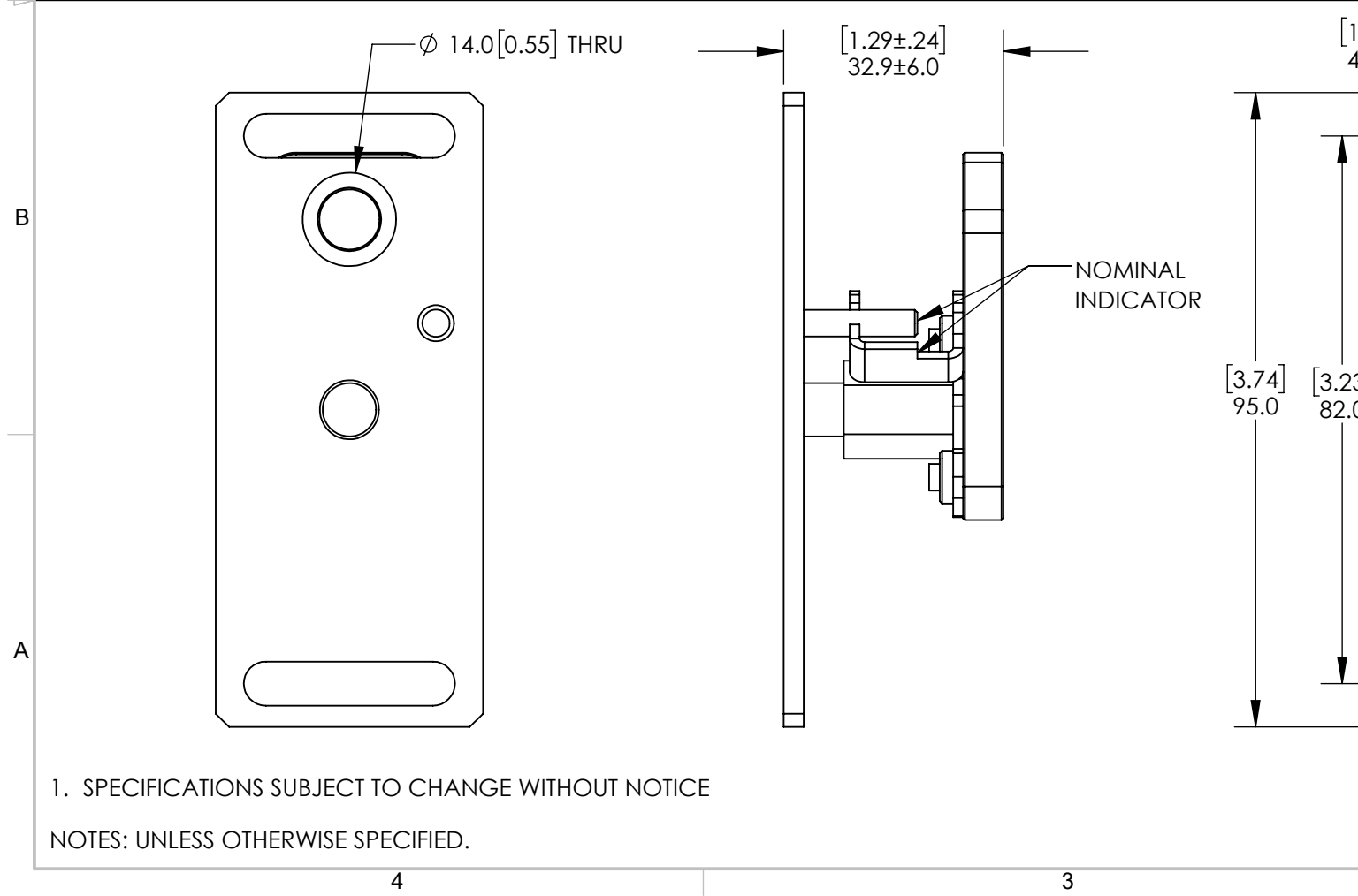
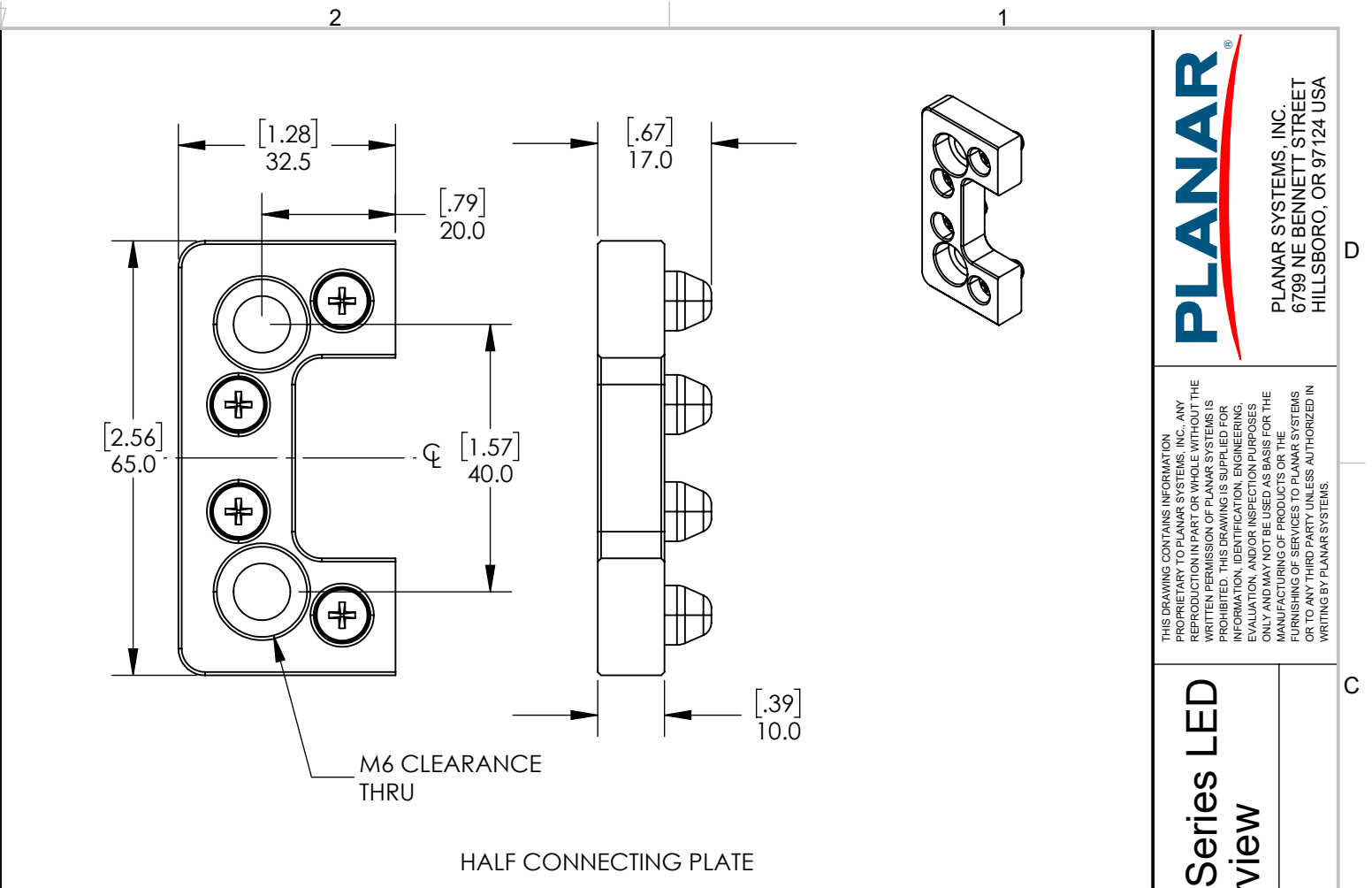
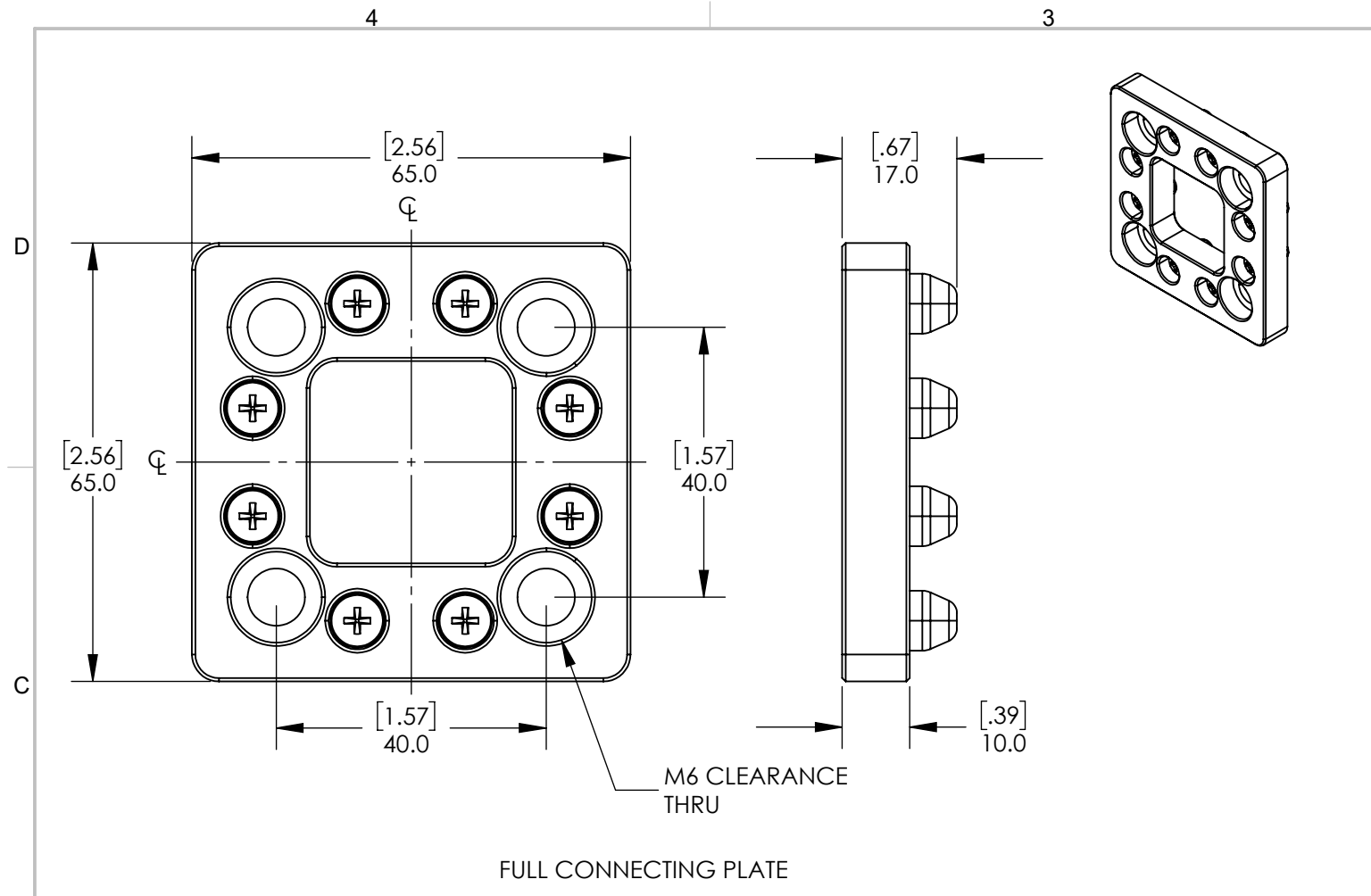

1. SPECIFICATIONS SUBJECT TO CHANGE WITHOUT NOTICE  
 NOTES: UNLESS OTHERWISE SPECIFIED.

**PLANAR**  
 PLANAR SYSTEMS, INC.  
 6799 NE BENNETT STREET  
 HILLSBORO, OR 97124 USA

THIS DRAWING CONTAINS INFORMATION PROPRIETARY TO PLANAR SYSTEMS, INC. ANY REPRODUCTION IN PART OR WHOLE WITHOUT THE WRITTEN PERMISSION OF PLANAR SYSTEMS IS PROHIBITED. THIS DRAWING IS SUPPLIED FOR INFORMATION, IDENTIFICATION, ENGINEERING, EVALUATION, AND/OR INSPECTION PURPOSES ONLY AND MAY NOT BE USED AS BASIS FOR THE MANUFACTURING OF PRODUCTS OR THE DESIGN OF ANY THIRD PARTY UNLESS AUTHORIZED IN WRITING BY PLANAR SYSTEMS.

PRODUCT: **Planar® Komodo™ Series LED**  
**Product Overview**

SHEET TITLE: **KOMODO 0.7 MOUNT ACCESSORIES**  
 DRAWN BY: **JJG**  
 DRAWN DATE: **22 Aug 25**  
 SHEET: **8 OF 10**  
 SHEET SIZE: **B** REVISION: **C**

PART NO. -  
 UNLESS OTHERWISE SPECIFIED DIMENSIONS ARE IN MILLIMETERS (INCHES).

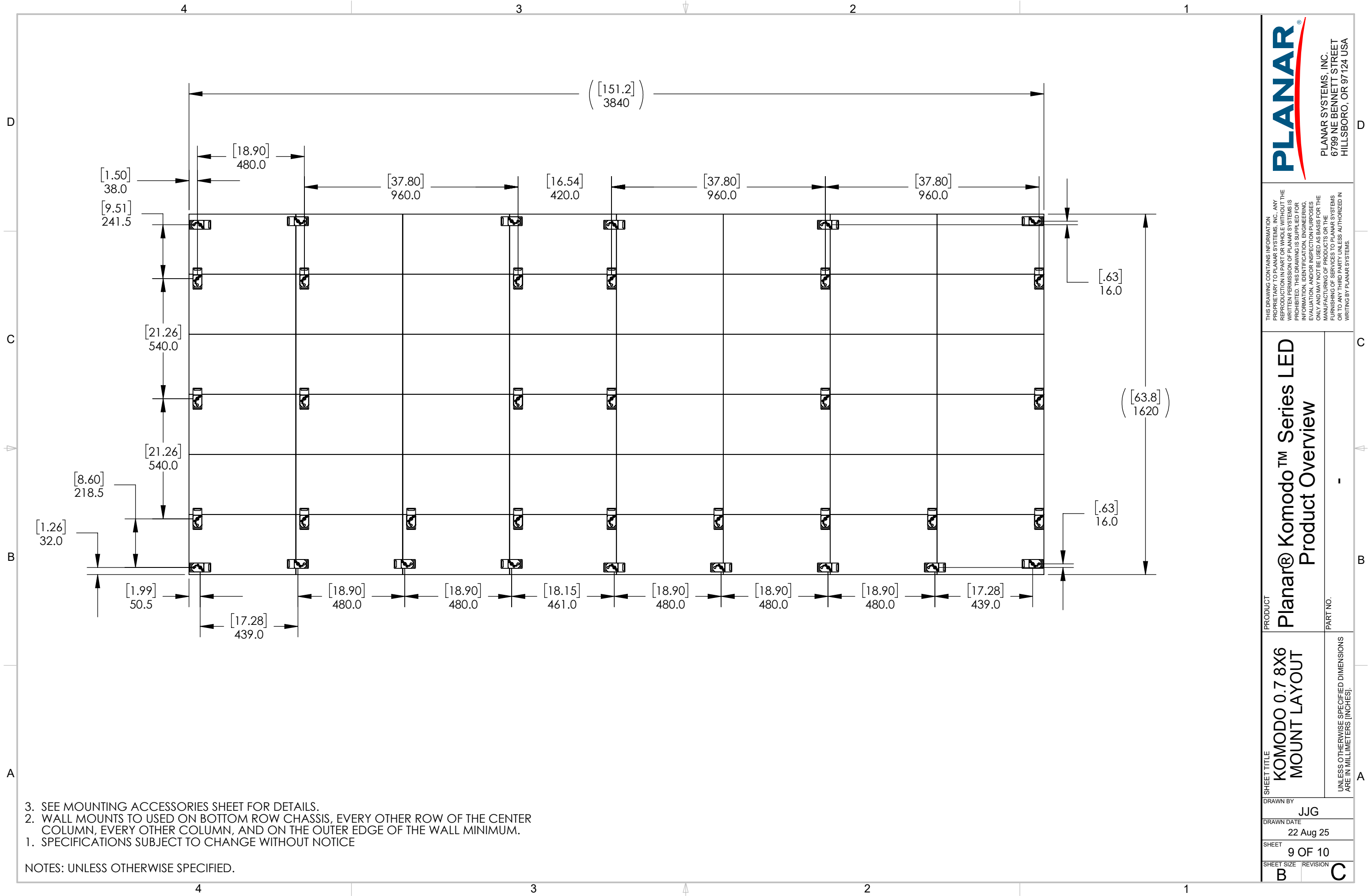

THIS DRAWING CONTAINS INFORMATION PROPRIETARY TO PLANAR SYSTEMS, INC. ANY REPRODUCTION IN PART OR WHOLE WITHOUT THE WRITTEN PERMISSION OF PLANAR SYSTEMS IS PROHIBITED. THIS DRAWING IS SUPPLIED FOR INFORMATION, IDENTIFICATION, ENGINEERING, EVALUATION, AND/OR INSPECTION PURPOSES ONLY AND MAY NOT BE USED AS BASIS FOR THE MANUFACTURING OF PRODUCTS OR THE DESIGN OF ANY THIRD PARTY UNLESS AUTHORIZED IN WRITING BY PLANAR SYSTEMS.

PRODUCT  
**Planar® Komodo™ Series LED Mount Layout**  
 PART NO. -

SHEET TITLE  
**KOMODO 0.7 8X6 MOUNT LAYOUT**  
 UNLESS OTHERWISE SPECIFIED DIMENSIONS ARE IN MILLIMETERS (INCHES).

DRAWN BY  
**JJG**  
 DRAWN DATE  
 22 Aug 25  
 SHEET  
 9 OF 10  
 SHEET SIZE REVISION  
**B C**

3. SEE MOUNTING ACCESSORIES SHEET FOR DETAILS.
2. WALL MOUNTS TO USED ON BOTTOM ROW CHASSIS, EVERY OTHER ROW OF THE CENTER COLUMN, EVERY OTHER COLUMN, AND ON THE OUTER EDGE OF THE WALL MINIMUM.
1. SPECIFICATIONS SUBJECT TO CHANGE WITHOUT NOTICE

NOTES: UNLESS OTHERWISE SPECIFIED.

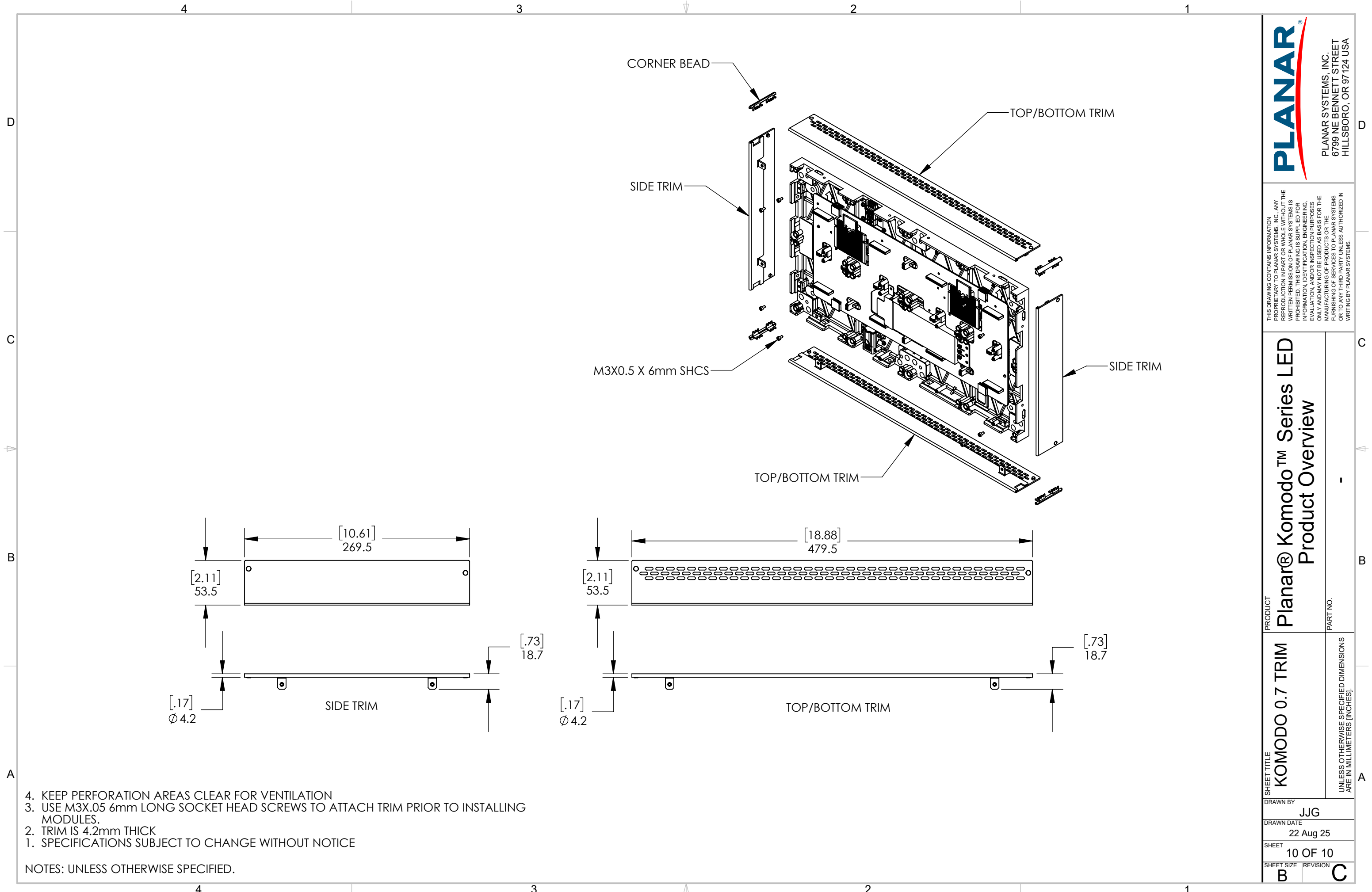

4. KEEP PERFORATION AREAS CLEAR FOR VENTILATION
3. USE M3X.05 6mm LONG SOCKET HEAD SCREWS TO ATTACH TRIM PRIOR TO INSTALLING MODULES.
2. TRIM IS 4.2mm THICK
1. SPECIFICATIONS SUBJECT TO CHANGE WITHOUT NOTICE

NOTES: UNLESS OTHERWISE SPECIFIED.

**PLANAR**

PLANAR SYSTEMS, INC.  
6799 NE BENNETT STREET  
HILLSBORO, OR 97124 USA

THIS DRAWING CONTAINS INFORMATION PROPRIETARY TO PLANAR SYSTEMS, INC. ANY REPRODUCTION IN PART OR WHOLE WITHOUT THE WRITTEN PERMISSION OF PLANAR SYSTEMS IS PROHIBITED. THIS DRAWING IS SUPPLIED FOR INFORMATION, IDENTIFICATION, ENGINEERING, EVALUATION, AND/OR INSPECTION PURPOSES ONLY AND MAY NOT BE USED AS BASIS FOR THE MANUFACTURING OF PRODUCTS OR THE DESIGN OF ANY PARTS OR SYSTEMS UNLESS AUTHORIZED IN WRITING BY PLANAR SYSTEMS.

PRODUCT  
**Planar® Komodo™ Series LED**  
Product Overview

PART NO.

SHEET TITLE  
**KOMODO 0.7 TRIM**

UNLESS OTHERWISE SPECIFIED DIMENSIONS ARE IN MILLIMETERS (INCHES).

DRAWN BY  
JJG

DRAWN DATE  
22 Aug 25

SHEET  
10 OF 10

SHEET SIZE REVISION

B

C